

POWERED BY



AL5DM-PSA

7-16 DIN Male Positive Stop™ for 7/8 in AL5-50 and AVA5-50 cable

## General Specifications

Interface	7-16 DIN Male
Body Style	Straight
Brand	HELIAX®   Positive Stop™
Mounting Angle	Straight

## Electrical Specifications

Connector Impedance	50 ohm
Operating Frequency Band	0 – 5200 MHz
Cable Impedance	50 ohm
3rd Order IMD, typical	-120 dBm @ 910 MHz
3rd Order IMD Test Method	Two +43 dBm carriers
RF Operating Voltage, maximum (vrms)	1415.00 V
dc Test Voltage	4000 V
Outer Contact Resistance, maximum	1.50 mOhm
Inner Contact Resistance, maximum	0.40 mOhm
Insulation Resistance, minimum	5000 MOhm
Average Power	3.0 kW @ 900 MHz
Peak Power, maximum	40.00 kW
Insertion Loss, typical	0.05 dB
Shielding Effectiveness	-130 dB

AL5DM-PSA

POWERED BY



## Outline Drawing

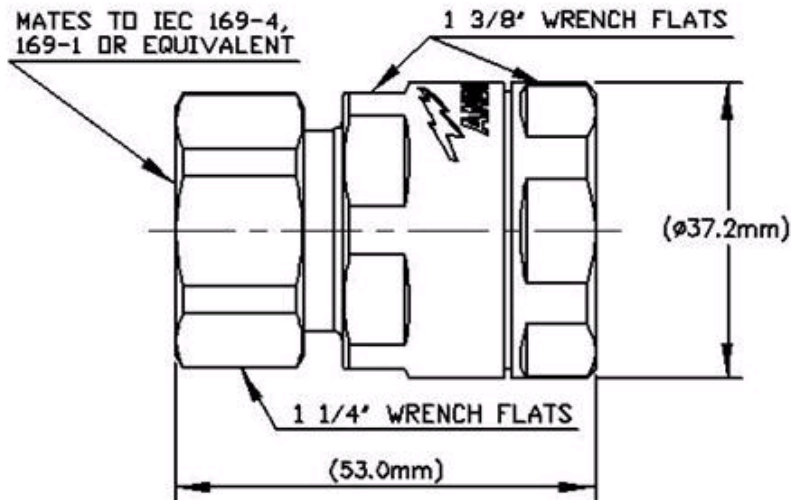

## Mechanical Specifications

Outer Contact Attachment Method	Ring-flare
Inner Contact Attachment Method	Captivated
Outer Contact Plating	Trimetal
Inner Contact Plating	Silver
Attachment Durability	25 cycles
Interface Durability	500 cycles
Interface Durability Method	IEC 61169-4:9.5
Connector Retention Tensile Force	1334 N   300 lbf
Connector Retention Torque	8.13 N-m   72.00 in lb
Insertion Force	200.17 N   45.00 lbf
Insertion Force Method	IEC 61169-1:15.2.4
Pressurizable	No
Coupling Nut Proof Torque	24.86 N-m   220.00 in lb
Coupling Nut Retention Force	1000.85 N   225.00 lbf
Coupling Nut Retention Force Method	MIL-C-39012C-3.25, 4.6.22

## Dimensions

Nominal Size	7/8 in
Diameter	37.20 mm   1.46 in
Length	52.95 mm   2.08 in
Weight	198.00 g   0.44 lb

## Environmental Specifications

Operating Temperature	-55 °C to +85 °C (-67 °F to +185 °F)
-----------------------	--------------------------------------

AL5DM-PSA



Storage Temperature	-55 °C to +85 °C (-67 °F to +185 °F)
Immersion Depth	1 m
Immersion Test Mating	Unmated
Immersion Test Method	IEC 60529:2001, IP68
Water Jetting Test Mating	Unmated
Water Jetting Test Method	IEC 60529:2001, IP66
Moisture Resistance Test Method	MIL-STD-202F, Method 106F
Mechanical Shock Test Method	MIL-STD-202F, Method 213B, Test Condition C
Thermal Shock Test Method	MIL-STD-202F, Method 107G, Test Condition A-1, Low Temperature -55 °C
Vibration Test Method	IEC 60068-2-6
Corrosion Test Method	MIL-STD-1344A, Method 1001.1, Test Condition A

## Standard Conditions

Attenuation, Ambient Temperature	20 °C   68 °F
Average Power, Ambient Temperature	40 °C   104 °F

## Return Loss/VSWR

Frequency Band	VSWR	Return Loss (dB)
45–1000 MHz	1.02	39.00
1010–2200 MHz	1.03	37.50
2210–3000 MHz	1.03	35.60
3010–5200 MHz	1.08	28.00

## Regulatory Compliance/Certifications

Agency	Classification
RoHS 2011/65/EU	Compliant by Exemption
China RoHS SJ/T 11364-2006	Above Maximum Concentration Value (MCV)
ISO 9001:2008	Designed, manufactured and/or distributed under this quality management system



## \* Footnotes

Immersion Depth	Immersion at specified depth for 24 hours
Insertion Loss, typical	$0.05\sqrt{\text{freq}}$ (GHz) (not applicable for elliptical waveguide)