

M57745

430-450MHz, 12.5V, 33W, SSB MOBILE RADIO

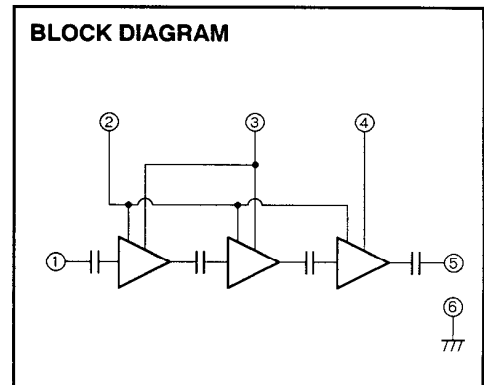
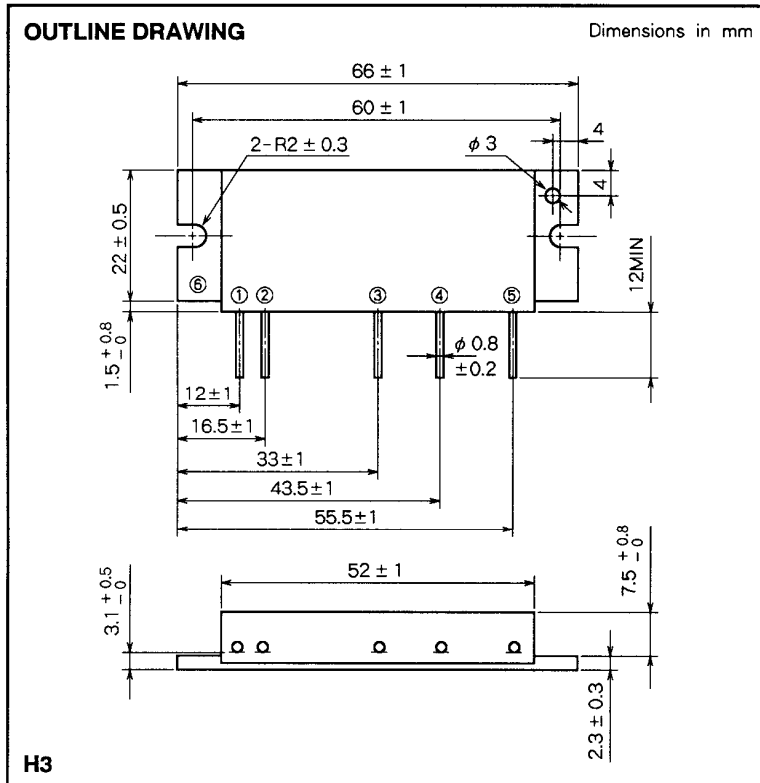

- PIN :
- ① Pin : RF INPUT
 - ② V_{BB} : BASE BIAS SUPPLY
 - ③ V_{CC1} : 1st. DC SUPPLY
 - ④ V_{CC2} : 2nd. DC SUPPLY
 - ⑤ P_O : RF OUTPUT
 - ⑥ GND : FIN

ABSOLUTE MAXIMUM RATINGS (T_c = 25 °C unless otherwise noted)

Symbol	Parameter	Conditions	Ratings	Unit
V _{CC}	Supply voltage		17	V
V _{BB}	Base bias		10	V
I _{CC}	Total current		10	A
P _{in(max)}	Input power	Z _G = Z _L = 50 Ω	0.5	W
P _{O(max)}	Output power	Z _G = Z _L = 50 Ω	40	W
T _{C(OP)}	Operation case temperature		- 30 to 110	°C
T _{stg}	Storage temperature		- 40 to 110	°C

Note. Above parameters are guaranteed independently.

ELECTRICAL CHARACTERISTICS (T_c = 25 °C unless otherwise noted)

Symbol	Parameter	Test conditions	Limits		Unit
			Min	Max	
f	Frequency range		430	450	MHz
P _O	Output power	P _{in} = 0.3W	33		W
η _T	Total efficiency	V _{CC} = 12.5V	40		%
2f _o	2nd. harmonic	V _{BB} = 9V		- 30	dBc
3f _o	3rd. harmonic	Z _G = Z _L = 50 Ω		- 30	dBc
ρ _{in}	Input VSWR			2.5	-
-	Load VSWR tolerance	V _{CC} = 15.2V, V _{BB} = 9V P _O = 30W (P _{in} : controlled) Load VSWR = 8.8 : 1 (All phase), Z _G = 50 Ω	No degradation or destroy		-

Note. Above parameters, ratings, limits and conditions are subject to change.

TYPICAL PERFORMANCE DATA

OUTPUT POWER, LINEAR POWER GAIN, TOTAL EFFICIENCY, INPUT VSWR VS. FREQUENCY

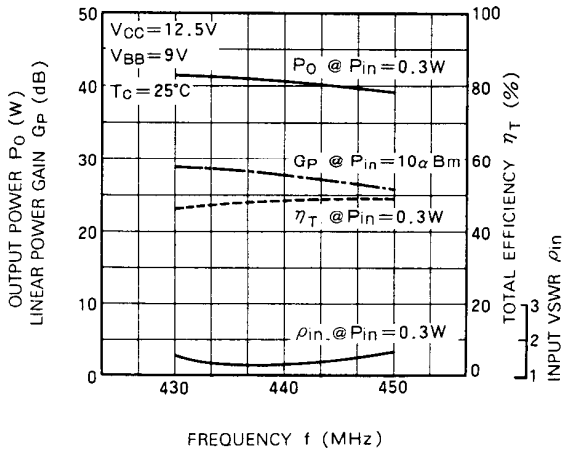

OUTPUT POWER, TOTAL COLLECTOR CURRENT, VS. INPUT POWER

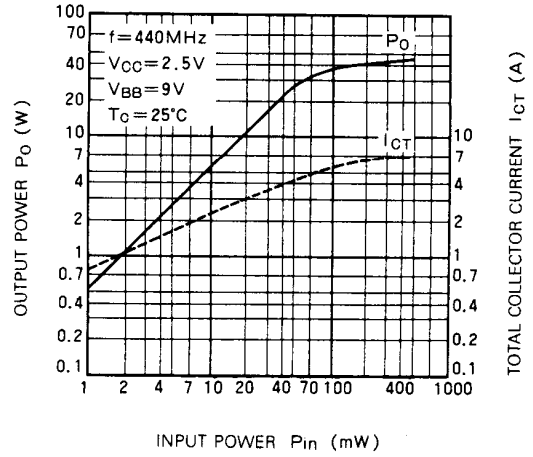

INTERMODULATION DISTORTION VS. OUTPUT POWER

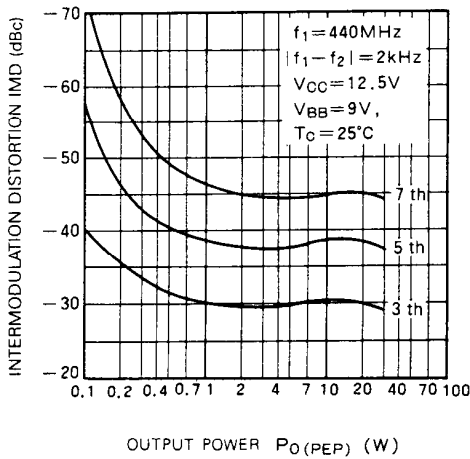

INPUT IMPEDANCE, OUTPUT IMPEDANCE VS. FREQUENCY

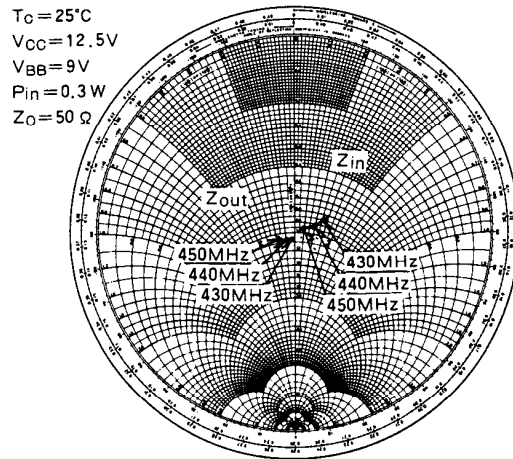

Note 2: Output power of the second stage transistor

Note 3: Circuit current of the first stage transistor

Note 4: Circuit current of the second stage transistor

Note 5: Circuit current of the final stage transistor

- Junction temperature of the first stage transistor
$$T_{j1} = (V_{CC} \times I_{T1} - P_{O1} + P_{in}) \times R_{th(j-c)1} + T_C^{(6)}$$
$$= (12.5 \times 0.35 - 2 + 0.3) \times 12 + T_C$$
$$= 32 + T_C \text{ (}^\circ\text{C)}$$

Note 6: Package temperature of device

- Junction temperature of the second stage transistor
$$T_{j2} = (V_{CC} \times I_{T2} - P_{O2} + P_{O1}) \times R_{th(j-c)2} + T_C$$
$$= (12.5 \times 1.32 - 8 + 2) \times 4 + T_C$$
$$= 42 + T_C \text{ (}^\circ\text{C)}$$
- Junction temperature of the final stage transistor
$$T_{j3} = (V_{CC} \times I_{T3} - P_O + P_{O2}) \times R_{th(j-c)3} + T_C$$
$$= (12.5 \times 4.33 - 30 + 8) \times 1.75 + T_C$$
$$= 56 + T_C \text{ (}^\circ\text{C)}$$