



## SD2942

### RF Power Transistors HF/VHF/UHF N - Channel MOSFETs

#### General Features

- GOLD METALLIZATION
- EXCELLENT THERMAL STABILITY
- COMMON SOURCE CONFIGURATION, PUSH PULL
- $P_{OUT} = 350W$  MIN. WITH 15dB GAIN @ 175MHz
- LOW  $R_{DS(on)}$

#### Description

The SD2942 is a gold metallized N-Channel MOS field-effect RF power transistor. The SD2942 offers 25% lower  $R_{ds(ON)}$  than industry standard and 20% higher power saturation than ST SD2932. These characteristics make the SD2942 ideal for 50V DC very high power application up to 250 MHz.

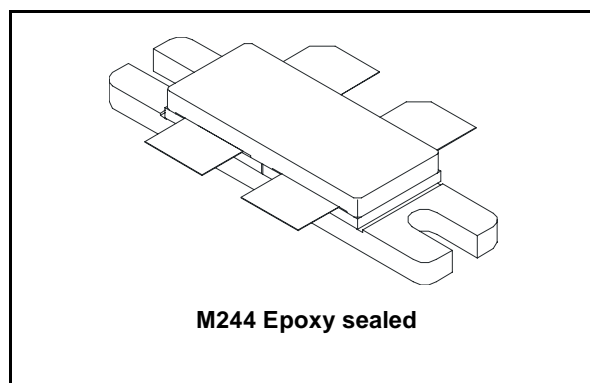

#### Pin Connection

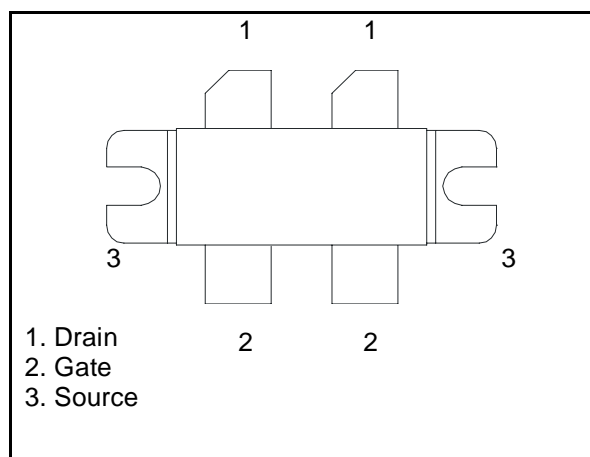

#### Order Codes

Part Number	Marking	Package	Packaging
SD2942	SD2942	M244	Plastic Tray

---

## Contents

<b>1</b>	<b>Electrical Data</b> .....	<b>3</b>
1.1	Maximum Rating .....	3
1.2	Thermal Data .....	3
1.3	Electrical Characteristics ( $T_{CASE} = 25^{\circ}C$ ) .....	4
<b>2</b>	<b>Impedance</b> .....	<b>5</b>
<b>3</b>	<b>Typical Performance</b> .....	<b>6</b>
<b>4</b>	<b>Test Circuit</b> .....	<b>8</b>
<b>5</b>	<b>Mechanical Data</b> .....	<b>11</b>
<b>6</b>	<b>Revision History</b> .....	<b>12</b>

# 1 Electrical Data

## 1.1 Maximum Rating

**Table 1. Absolute Maximum Rating ( $T_{CASE} = 25^{\circ}C$ )**

Symbol	Parameter	Value	Unit
$V_{(BR)DSS}^{(1)}$	Drain Source Voltage	130	V
$V_{DGR}^{(1)}$	Drain-Gate Voltage ( $R_{GS} = 1M\Omega$ )	130	V
$V_{GS}$	Gate-Source Voltage	$\pm 20$	V
$I_D$	Drain Current	40	A
$P_{DISS}$	Power Dissipation	500	W
$T_J$	Max. Operating Junction Temperature	+200	$^{\circ}C$
$T_{STG}$	Storage Temperature	-65 to +150	$^{\circ}C$

1.  $T_J = 150^{\circ}C$

## 1.2 Thermal Data

**Table 2. Thermal data**

Symbol	Parameter	Value	Unit
$R_{thJC}$	Junction to Case thermal resistance	0.35	$^{\circ}C/W$

### 1.3 Electrical Characteristics ( $T_{CASE} = 25^{\circ}C$ )

**Table 3. Static** (per section)

Symbol	Test Conditions		Min.	Typ.	Max.	Unit
$V_{(BR)DSS}^{(1)}$	$V_{GS} = 0 V$	$I_{DS} = 100 mA$	130			V
$I_{DSS}$	$V_{GS} = 0 V$	$V_{DS} = 50 V$			50	$\mu A$
$I_{GSS}$	$V_{GS} = 20 V$	$V_{DS} = 0 V$			250	nA
$V_{GS(Q)}$	$V_{DS} = 10 V$	$I_D = 250 mA$	1.5		4	V
$V_{DS(ON)}$	$V_{GS} = 10 V$	$I_D = 10 A$			3.0	V
$G_{FS}$	$V_{DS} = 10 V$	$I_D = 5 A$	5			mho
$C_{ISS}$	$V_{GS} = 0 V$	$V_{DS} = 50 V$		415		pF
$C_{OSS}$	$V_{GS} = 0 V$	$V_{DS} = 50 V$		236		pF
$C_{RSS}$	$V_{GS} = 0 V$	$V_{DS} = 50 V$		17		pF

1.  $T_J = 150^{\circ}C$

**Table 4. Dynamic**

Symbol	Test Conditions		Min.	Typ.	Max.	Unit
$P_{OUT}$	$V_{DD} = 50 V$	$I_{DQ} = 500 mA$ $f = 175MHz$	350			W
$G_{PS}$	$V_{DD} = 50 V$	$I_{DQ} = 500 mA$ $P_{OUT} = 350 W$ $f = 175MHz$	15	17		dB
$\eta_D$	$V_{DD} = 50 V$	$I_{DQ} = 500 mA$ $P_{OUT} = 350 W$ $f = 175MHz$	55	61		%
Load Mismatch	$V_{DD} = 50 V$	$I_{DQ} = 500 mA$ $P_{OUT} = 350 W$ $f = 175MHz$ All Phase Angles	5:1			VSWR

## 2 Impedance

Figure 1. Impedance Data Schematic

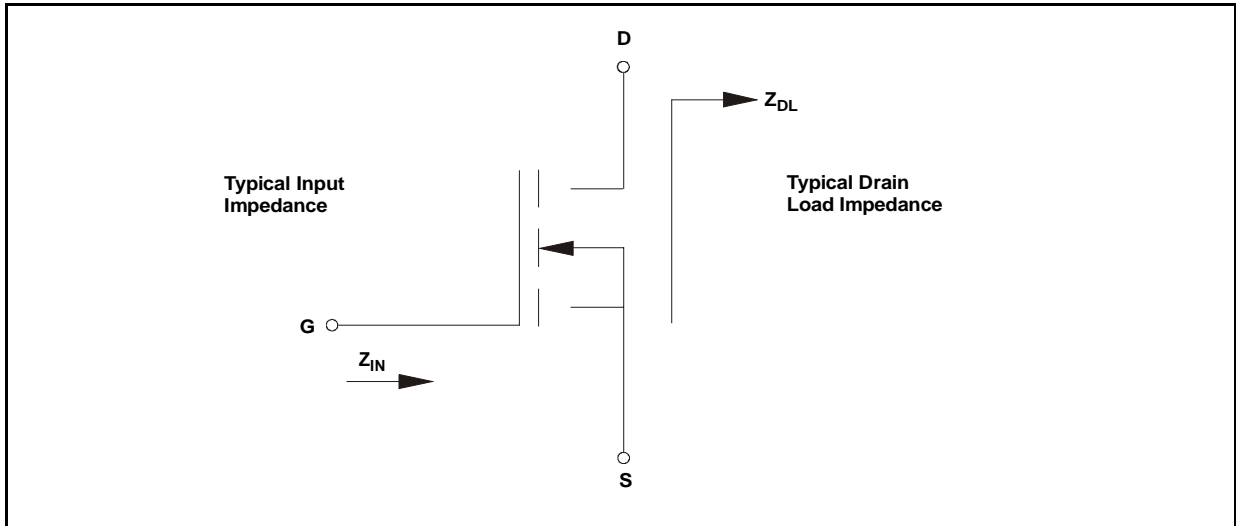

Table 5. Impedance Data

f	$Z_{IN}$ ( $\Omega$ )	$Z_{DL}$ ( $\Omega$ )
250 MHz	$1.3 - j 1.9$	$1.9 + j 3.2$
230 MHz	$1.2 - j 1.8$	$2.1 + j 3.7$
200 MHz	$1.1 - j 1.6$	$2.7 + j 4.2$
175 MHz	$1.0 - j 1.4$	$3.3 + j 4.8$
100 MHz	$1.8 - j 2.5$	$7.5 + j 9$
50 MHz	$3.2 - j 4.4$	$10 + j 12$

### 3 Typical Performance

Figure 2. Capacitance Vs Drain Voltage

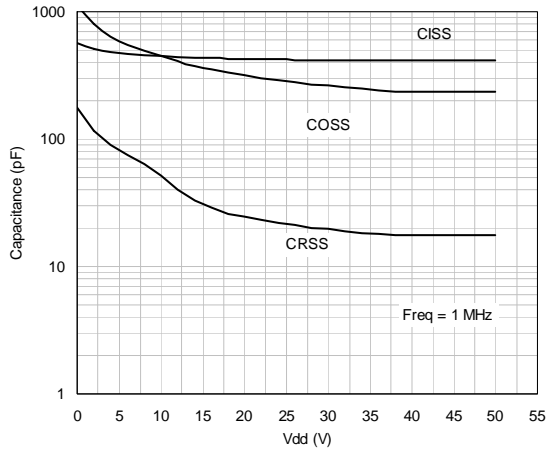

Figure 3. Drain Current Vs Gate Voltage

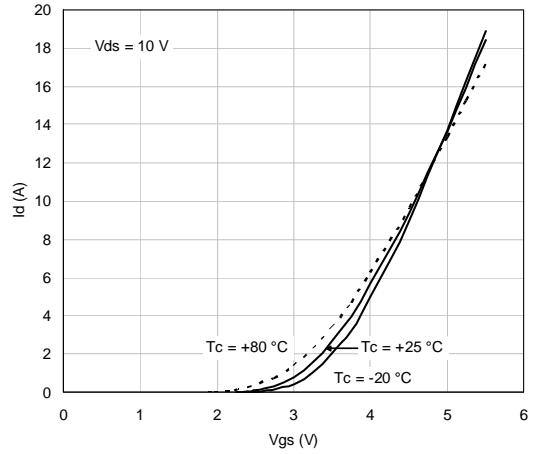

Figure 4. Gate Source Voltage Vs Case Temp. Figure 5. Safe Operating Area

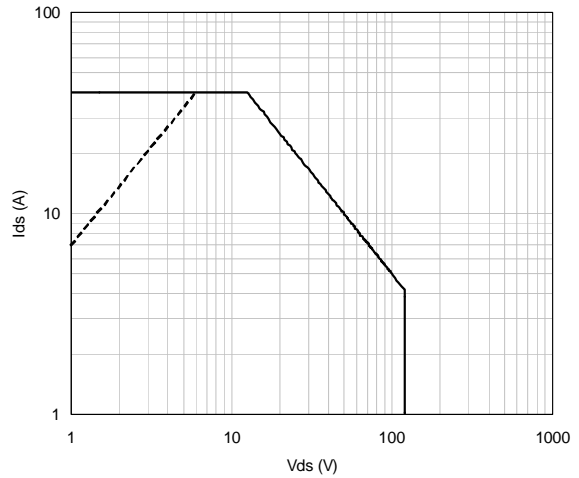
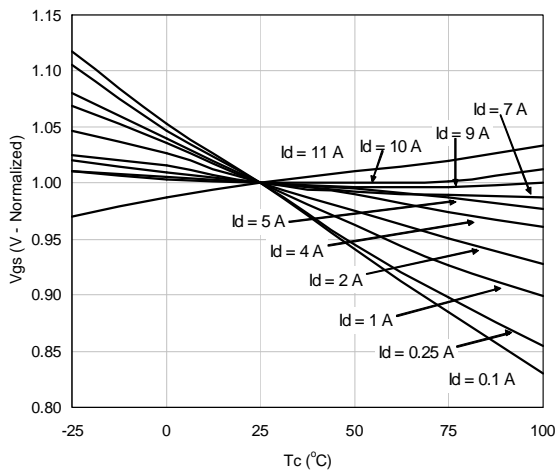

Figure 6. Power Gain Vs Pout and Case Temp. Figure 7. Efficiency Vs Pout and Case Temp.

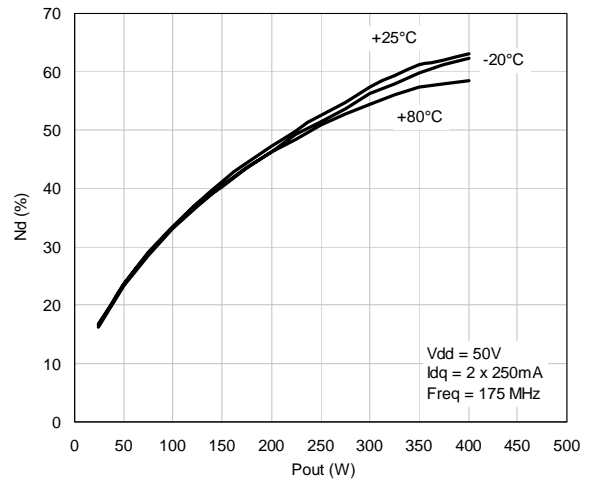
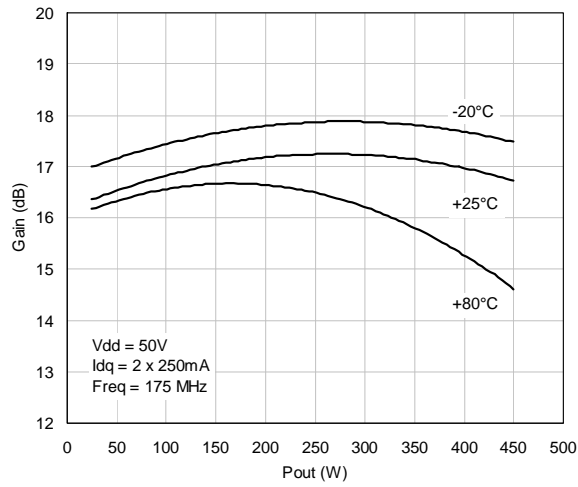

Figure 8. Pout Vs Input Power and Case Temp Figure 9. Pout Vs Input Power & Drain Voltage

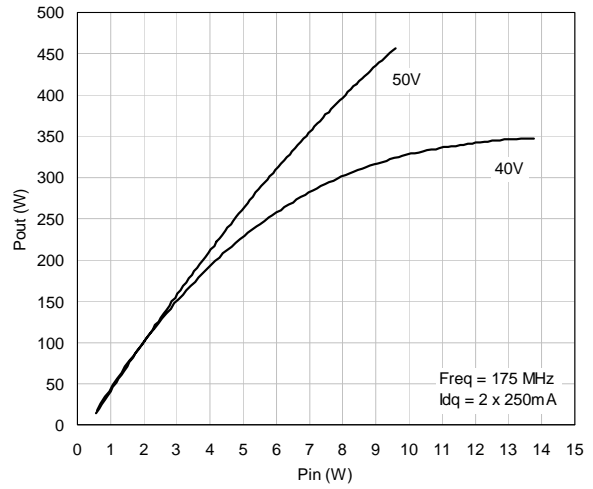
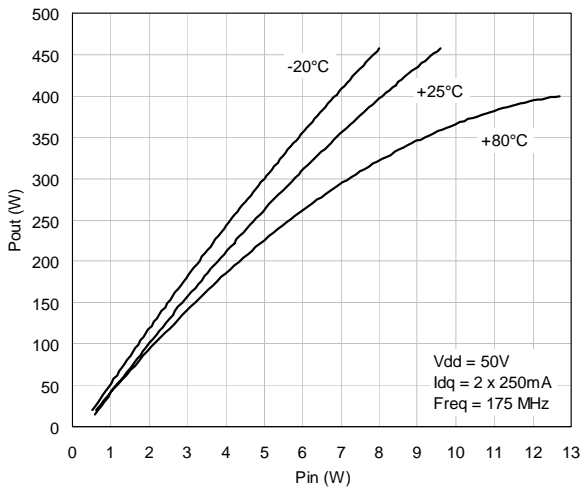

Figure 10. Pout Vs Gate Voltage & Case Temp. Figure 11. Pout Vs Drain Voltage & Input Power

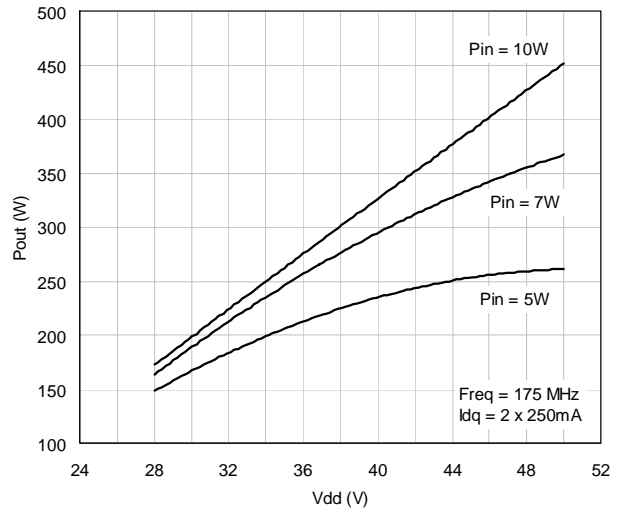
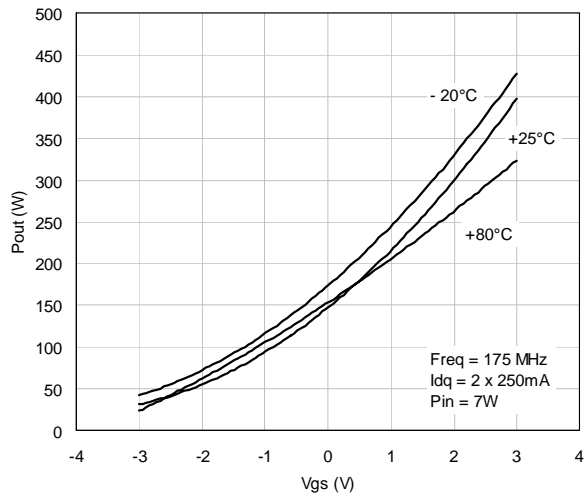
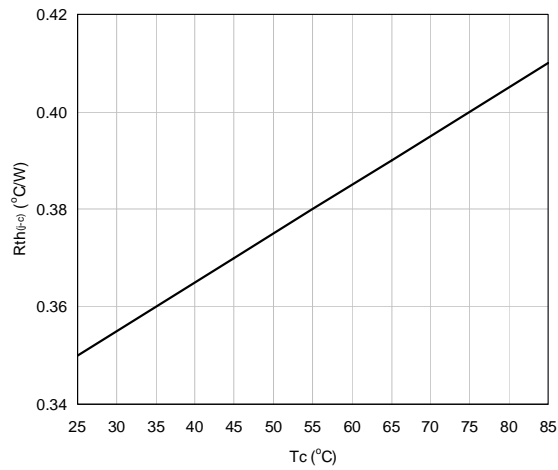
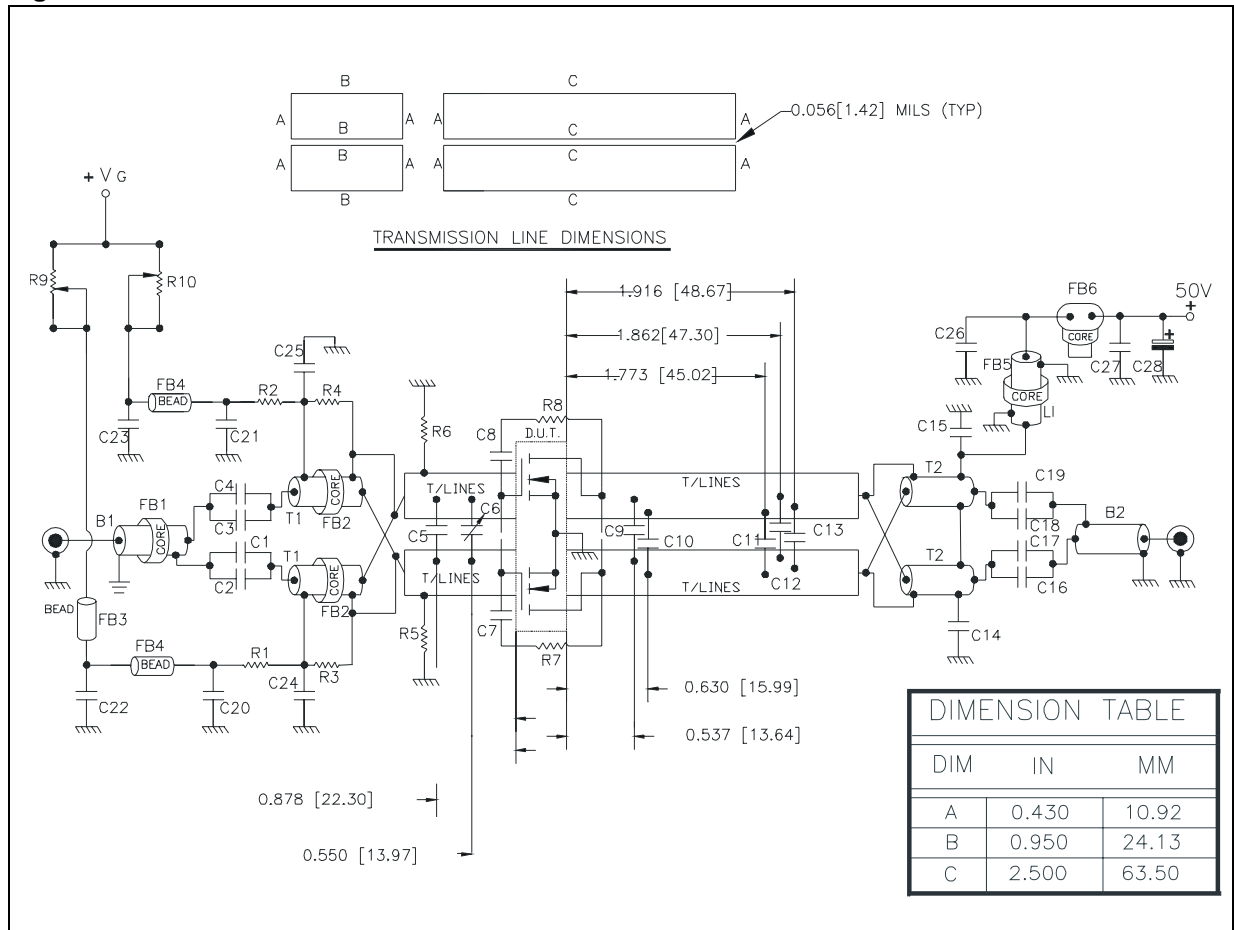

Figure 12. Max. Therm. Resist Vs Case Temp.



# 4 Test Circuit

Figure 13. 175 MHz Test Circuit Schematic



- Note: 1 Dimension at component symbol are reference for component placement.  
 2 Gap between ground and transmission lines is + 0.002{0.05} - 0.000{0.00} Typ.

**Table 6. 175 MHz Test Circuit Component Part List**

Symbol	Description
R1,R2,R5,R6	470 $\Omega$ 1 W, Surface Mount Chip Resistor
R3,R4	360 $\Omega$ 0.5 W, Carbon Comp. Axial Lead Resistor or Equivalent
R7,R8	560 $\Omega$ 2 W, Resistor Two Turn Wire Air-Wound Axial Lead Resistor
R9,R10	20 K $\Omega$ 3.09 W, 10 Turn Wirewound Precision Potentiometer
C1,C4	680 pF ATC 130B Surface Mount Ceramic Chip Capacitor
C2,C3,C7,C8,C17,C19,C20,C21	10000 pF ATC 200B Surface Mount Ceramic Chip Capacitor
C5	75 pF ATC 100B Surface Mount Ceramic Chip Capacitor
C6	ST40 25 pF - 115 pF Miniature variable Trimmer
C9,C10	47 pF ATC 100B Surface Mount Ceramic Chip Capacitor
C11,C12, C13	43 pF ATC 100B Surface Mount Ceramic Chip Capacitor
C14,C15,C24,C25	1200 pF ATC 700B Surface Mount Ceramic Chip Capacitor
C16,C18	470 pF ATC 700B Surface Mount Ceramic Chip Capacitor
C22,C23	0.1 $\mu$ F / 500 V Surface Mount Ceramic Chip Capacitor
C26,C27	0.01 $\mu$ F / 500 V Surface Mount Ceramic Chip Capacitor
C28	10 $\mu$ F / 63 Aluminum Electrolytic Axial Lead Capacitor
B1	50 $\Omega$ RG316 O.D 0.076[1.93] L = 11.80[299.72] Flexible Coaxial Cable 4 Turns thru Fair-rite Bead
B2	50 $\Omega$ RG-142B O.D 0.165[4.19] L = 11.80[299.72] Flexible Coaxial Cable
T1	R.F. Transformer 4:1, 25 $\Omega$ O.D RG316-25 O.D 0.080[2.03] L = 5.90[149.86] Flexible Coaxial Cable 2 Turns thru Fair-rite Multi-Aperture Core
T2	R.F. Transformer 1:4, 25 $\Omega$ Semi-rigid Coaxial Cable O.D. 0.141[3.58] L = 5.90[149.86]
L1	Inductor $\lambda$ 1/4 Wave 50 $\Omega$ O.D 0.165[4.19] L = 11.80 [299.72] Flexible Coaxial Cable 2 Turns thru Fair-rite Bead
FB1,FB5	Shield Bead
FB2,FB6	Multi-aperture Core
FB3	Multilayer Ferrite Chip Bead (Surface Mount)
FB4	Surface Mount Emi Shield Bead
PCB	Woven Glass Reinforced PTFE Microwave Laminate 0.06", 1 oz EDCu, Both sides, $\epsilon_r = 2.55$

Figure 14. 175 MHz Test Circuit Photomaster

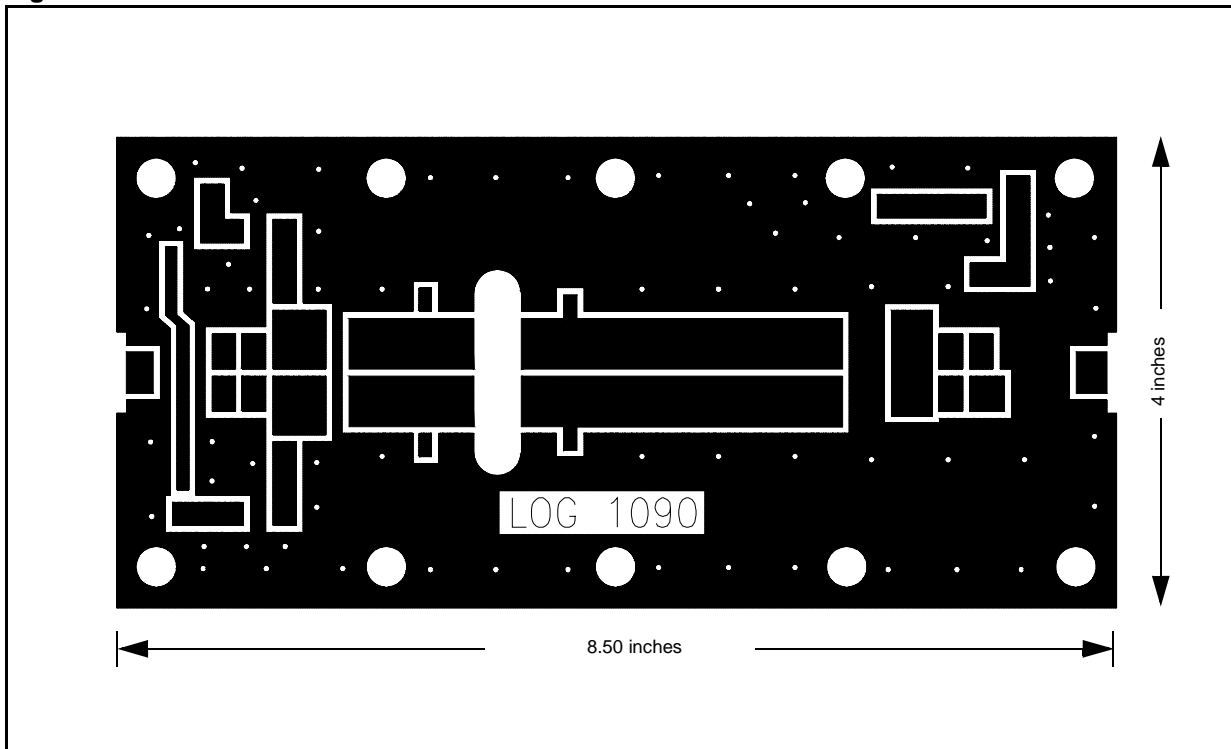
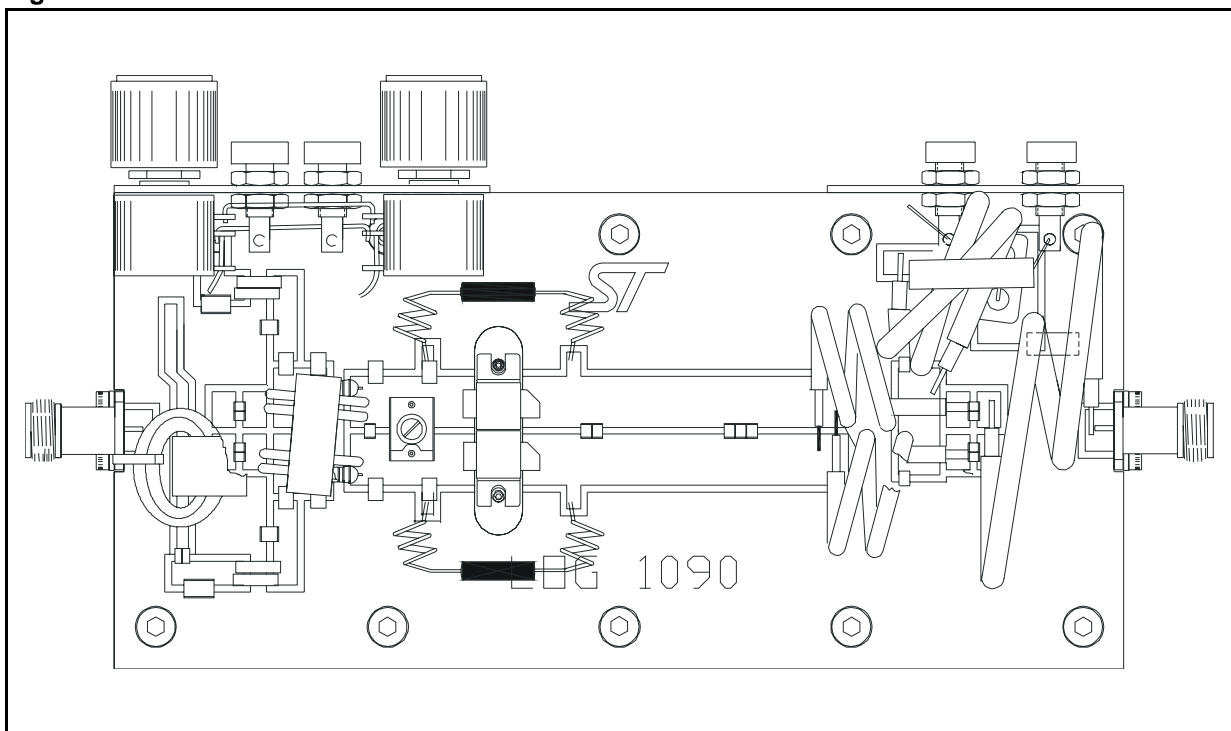

Figure 15. 175 MHz Test Circuit



# 5 Mechanical Data

**Table 7. M244 (.400 x .860 4/L BAL N/HERM W/FLG)**

DIM.	mm.			inch		
	MIN.	TYP	MAX.	MIN.	TYP	MAX.
A	5.59		5.84	0.220		0.230
B		5.08			0.200	
C	3.02		3.28	0.119		0.129
D	9.65		9.91	0.380		0.390
E	19.81		20.82	0.780		0.820
F	10.92		11.18	0.430		0.440
G		27.94			1.100	
H	33.91		34.16	1.335		1.345
I	0.10		0.15	0.004		0.006
J	1.52		1.78	0.060		0.070
K	2.59		2.84	0.102		0.112
L	4.83		5.84	0.190		0.230
M	10.03		10.34	0.395		0.407
N	21.59		22.10	0.850		0.870

**Figure 16. M244 Package Dimensions**

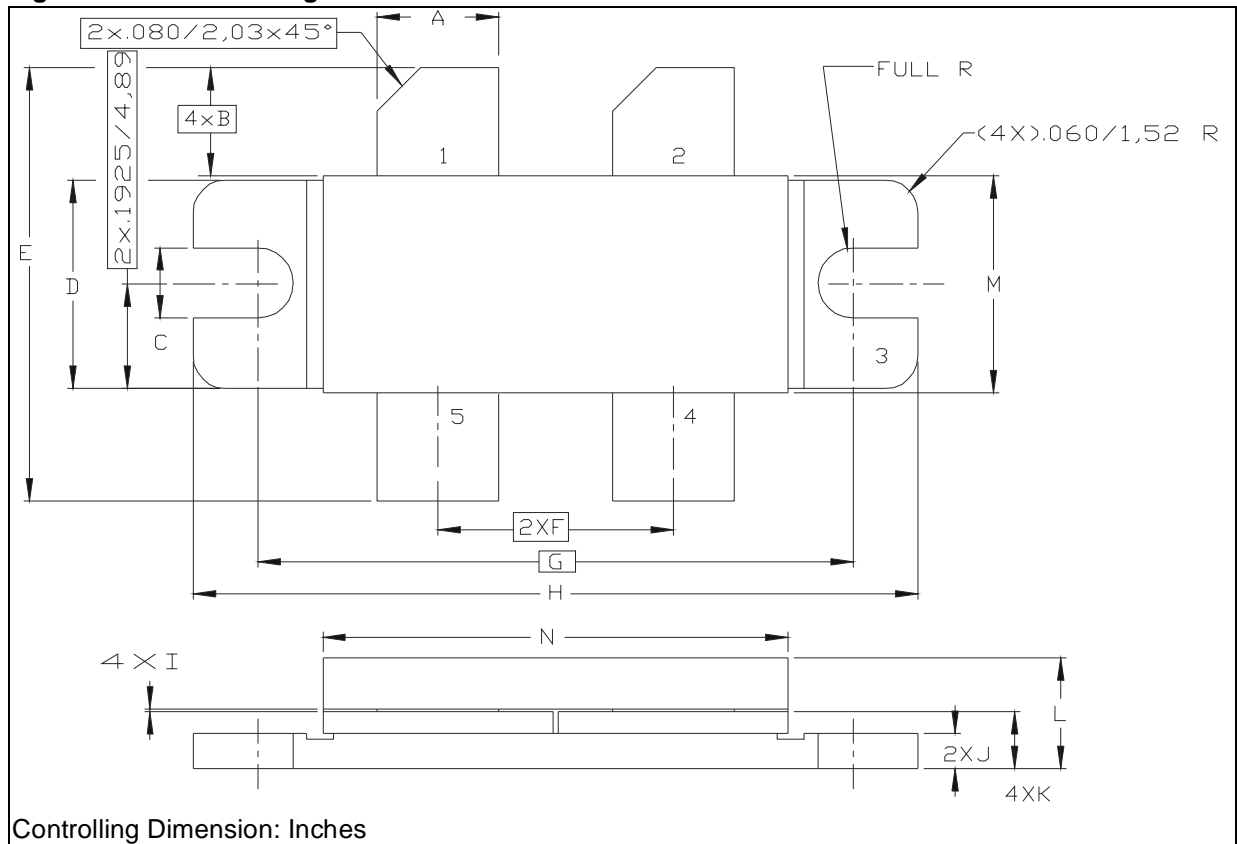

## 6 Revision History

Date	Revision	Description of Changes
18 Oct 2005	1	First Issue.

Information furnished is believed to be accurate and reliable. However, STMicroelectronics assumes no responsibility for the consequences of use of such information nor for any infringement of patents or other rights of third parties which may result from its use. No license is granted by implication or otherwise under any patent or patent rights of STMicroelectronics. Specifications mentioned in this publication are subject to change without notice. This publication supersedes and replaces all information previously supplied. STMicroelectronics products are not authorized for use as critical components in life support devices or systems without express written approval of STMicroelectronics.

The ST logo is a registered trademark of STMicroelectronics.  
All other names are the property of their respective owners

© 2005 STMicroelectronics - All rights reserved

STMicroelectronics group of companies

Australia - Belgium - Brazil - Canada - China - Czech Republic - Finland - France - Germany - Hong Kong - India - Israel - Italy - Japan -  
Malaysia - Malta - Morocco - Singapore - Spain - Sweden - Switzerland - United Kingdom - United States of America

[www.st.com](http://www.st.com)