



A Division of RF Industries

UHF Connectors for Heliax®

Heliax is a registered trademark of Andrew Corporation



RFU-502-H1



RFU-520-H1

Tools and Materials Required for Assembly

- File, flat or RFA-4420 Cable Devil
- Wrench: (2) 13/16 in
- Razor Knife
- Hacksaw, fine-toothed blade
- Wire brush, small
- Silicone grease

Read Instructions Thoroughly Before Assembly

Step 1. Prepare Cable. End of cable must be straight for at least 10 in (254mm). Remove jacket to approximate dimension shown. Use knife. Deburr sharp end of cut outer conductor.

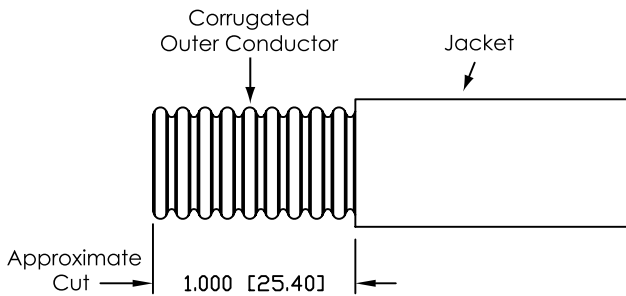

Step 2. Make second jacketing cut. Scribe line on ridge of exposed corrugated outer conductor. Line must be at least 13/32 in (10mm) from end of cable. Remove jacket to dimension shown using straight-edged piece of heavy paper wrapped around cable to guide cut.

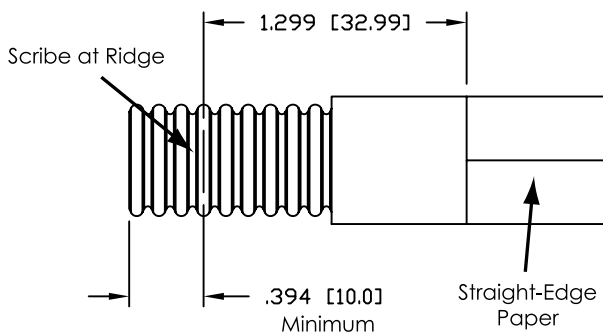

Step 3. Install gasket. Add thin O-ring gasket to second fully-exposed corrugation groove from jacket. Apply thin coating of silicone grease to outer surface of gasket and gasket lead chamfer in clamping nut using finger tip. Do not allow silicone grease on threads of clamping nut.

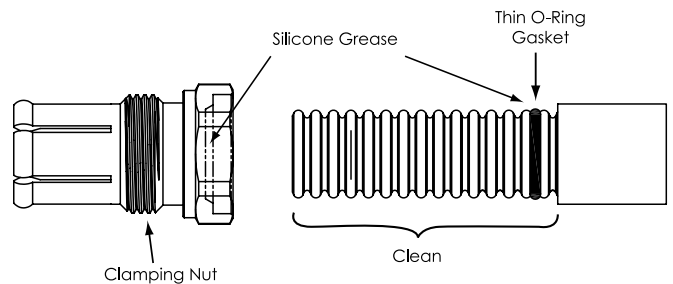

Step 4. Add clamping nut and cut cable. Push clamping nut on cable. Use twisting motion to assure spring contacts snap into groove. Refer to cutaway view in Step 6. Grip clamping nut with one hand and align edge with scribed line. Then carefully cut outer conductor and foam dielectric material flush with end of clamping nut, exposing center conductor. Make shallow cut; do not damage center conductor. Use hacksaw with fine-toothed blade or model maker's saw.

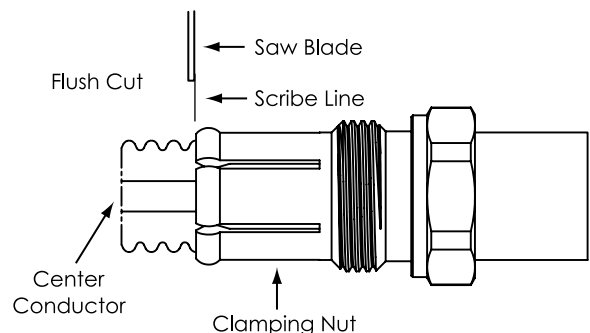

Continued on back →

Step 5. Trim center conductor. Cut center conductor to length shown. Use file to deburr cut end of center conductor.

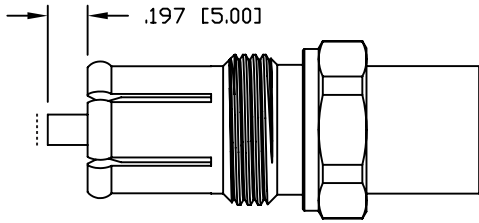

Step 6. Detach foam dielectric. Separate all foam dielectric completely from edge of outer conductor to assure good electrical contact with outer body. Refer to enlarged cutaway view in Step 7 which illustrates positive grip of outer conductor between clamping nut and outer body. Use tip of knife and work around entire circumference. Remove burrs from inside edge of outer conductor with knife. Use wire brush to remove copper particles from foam.

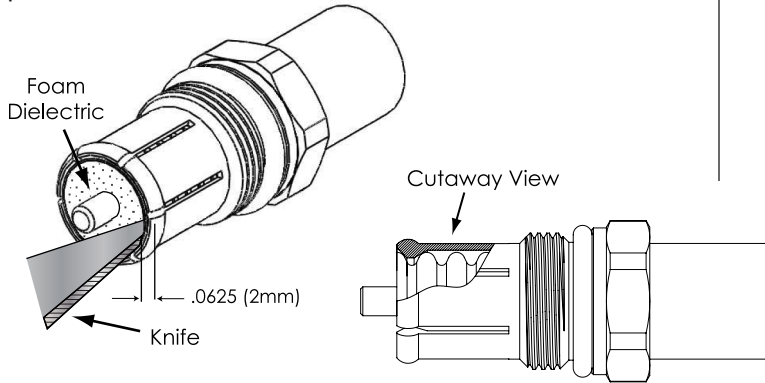

Step 7. Inspect contact surface. Thread outer body to clamping nut and tighten with wrenches. Turn outer body only; do not turn clamping nut. Disassemble connection to inspect for good metal-to-metal contact of flared outer conductor.

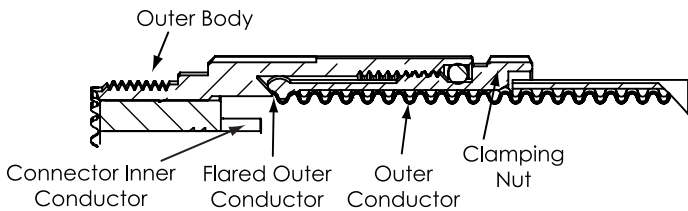

Step 8. Tighten clamp nut to outer body. Place thick O-ring gasket into groove in clamping nut. Add thin coating of silicone grease to outer surface of gasket. Do not allow silicone grease on threads of clamping nut. Slip the cable center conductor into connector inner conductor inside the outer body. Make certain connector is straight, i.e., square to flared outer conductor thread outer body onto clamping nut and tighten. Turn outer body only; do not turn clamping nut.

