

POWERED BY

**AL5E78-PS****7/8 in EIA Positive Stop™ for 7/8 in AVA5-50 and AL5-50 cable**

General Specifications

Interface	7/8 in EIA Flange
Body Style	Straight
Brand	HELIAX® Positive Stop™
Mounting Angle	Straight

Electrical Specifications

Connector Impedance	50 ohm
Operating Frequency Band	0 – 5000 MHz
Cable Impedance	50 ohm
3rd Order IMD, typical	-116 dBm @ 910 MHz
3rd Order IMD Test Method	Two +43 dBm carriers
RF Operating Voltage, maximum (vrms)	2120.00 V
dc Test Voltage	6000 V
Outer Contact Resistance, maximum	1.50 mOhm
Inner Contact Resistance, maximum	1.50 mOhm
Insulation Resistance, minimum	5000 MOhm
Average Power	2.3 kW @ 900 MHz
Peak Power, maximum	90.00 kW
Insertion Loss, typical	0.05 dB
Shielding Effectiveness	-130 dB

AL5E78-PS

POWERED BY



Outline Drawing

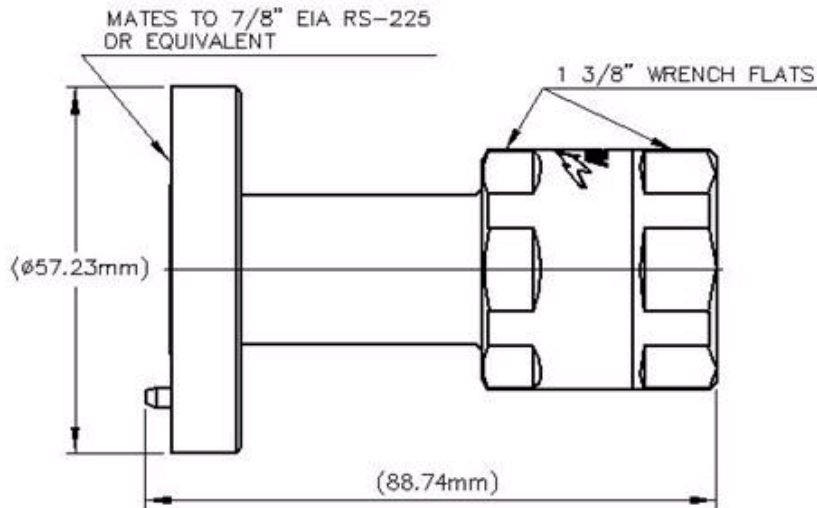

Mechanical Specifications

Outer Contact Attachment Method	Ring-flare
Inner Contact Attachment Method	Captivated
Outer Contact Plating	Trimetal
Inner Contact Plating	Silver
Attachment Durability	25 cycles
Interface Durability	50 cycles
Connector Retention Tensile Force	1335 N 300 lbf
Connector Retention Torque	8.10 N-m 71.69 in lb
Insertion Force	66.72 N 15.00 lbf
Insertion Force Method	IEC 61169-1:15.2.4
Pressurizable	No
Coupling Nut Proof Torque	24.86 N-m 220.00 in lb

Dimensions

Nominal Size	7/8 in
Diameter	57.23 mm 2.25 in
Length	88.74 mm 3.49 in
Weight	340.21 g 0.75 lb

Environmental Specifications

Operating Temperature	-55 °C to +85 °C (-67 °F to +185 °F)
Storage Temperature	-55 °C to +85 °C (-67 °F to +185 °F)
Immersion Depth	1 m
Immersion Test Mating	Unmated

AL5E78-PS



Immersion Test Method	IEC 60529:2001, IP68
Water Jetting Test Mating	Unmated
Water Jetting Test Method	IEC 60529:2001, IP66
Moisture Resistance Test Method	MIL-STD-202F, Method 106F
Mechanical Shock Test Method	MIL-STD-202, Method 213, Test Condition I
Thermal Shock Test Method	MIL-STD-202F, Method 107G, Test Condition A-1, Low Temperature -55 °C
Vibration Test Method	MIL-STD-202F, Method 204D, Test Condition B
Corrosion Test Method	MIL-STD-1344A, Method 1001.1, Test Condition A

Standard Conditions

Attenuation, Ambient Temperature	20 °C 68 °F
Average Power, Ambient Temperature	40 °C 104 °F

Return Loss/VSWR

Frequency Band	VSWR	Return Loss (dB)
50–1000 MHz	1.04	35.00
1700–2200 MHz	1.04	35.00
2400–2700 MHz	1.07	30.00
3400–3600 MHz	1.12	25.00

Regulatory Compliance/Certifications

Agency	Classification
RoHS 2011/65/EU	Compliant by Exemption
China RoHS SJ/T 11364-2006	Above Maximum Concentration Value (MCV)
ISO 9001:2008	Designed, manufactured and/or distributed under this quality management system



* Footnotes

Immersion Depth	Immersion at specified depth for 24 hours
Insertion Loss, typical	$0.05\sqrt{\text{freq (GHz)}}$ (not applicable for elliptical waveguide)