

POWERED BY

**AL7DF-PSA****7-16 DIN Female Positive Stop™ for 1-5/8 in cable**

General Specifications

Interface	7-16 DIN Female
Body Style	Straight
Brand	HELIAX® Positive Stop™
Mounting Angle	Straight

Electrical Specifications

Connector Impedance	50 ohm
Operating Frequency Band	0 – 2700 MHz
Cable Impedance	50 ohm
3rd Order IMD, typical	-120 dBm @ 910 MHz
3rd Order IMD Test Method	Two +43 dBm carriers
RF Operating Voltage, maximum (vrms)	1415.00 V
dc Test Voltage	4000 V
Outer Contact Resistance, maximum	1.50 mOhm
Inner Contact Resistance, maximum	0.80 mOhm
Insulation Resistance, minimum	5000 MOhm
Average Power	3.0 kW @ 900 MHz
Peak Power, maximum	40.00 kW
Insertion Loss, typical	0.05 dB
Shielding Effectiveness	-130 dB

AL7DF-PSA

POWERED BY



Outline Drawing

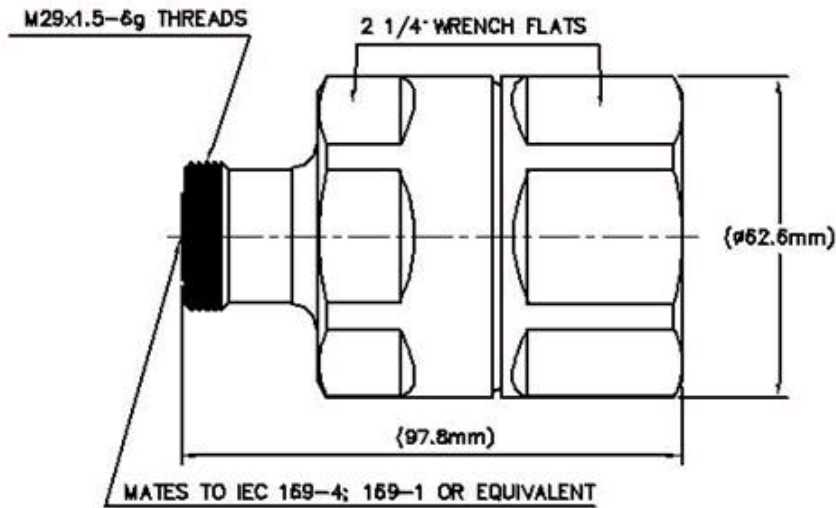

Mechanical Specifications

Outer Contact Attachment Method	Ring-flare
Inner Contact Attachment Method	Captivated
Outer Contact Plating	Trimetal
Inner Contact Plating	Silver
Attachment Durability	25 cycles
Interface Durability	50 cycles
Interface Durability Method	IEC 61169-4:9.5
Connector Retention Tensile Force	2224 N 500 lbf
Connector Retention Torque	13.56 N-m 120.00 in lb
Insertion Force	200.17 N 45.00 lbf
Insertion Force Method	IEC 61169-1:15.2.4
Pressurizable	No

Dimensions

Nominal Size	1-5/8 in
Diameter	62.74 mm 2.47 in
Length	97.82 mm 3.85 in
Weight	722.00 g 1.59 lb

Environmental Specifications

Operating Temperature	-55 °C to +85 °C (-67 °F to +185 °F)
Storage Temperature	-55 °C to +85 °C (-67 °F to +185 °F)
Immersion Depth	1 m
Immersion Test Mating	Unmated

AL7DF-PSA



Immersion Test Method	IEC 60529:2001, IP68
Water Jetting Test Mating	Unmated
Water Jetting Test Method	IEC 60529:2001, IP66
Moisture Resistance Test Method	MIL-STD-202F, Method 106F
Mechanical Shock Test Method	MIL-STD-202F, Method 213B, Test Condition C
Thermal Shock Test Method	MIL-STD-202F, Method 107G, Test Condition A-1, Low Temperature -55 °C
Vibration Test Method	IEC 60068-2-6
Corrosion Test Method	MIL-STD-1344A, Method 1001.1, Test Condition A

Standard Conditions

Attenuation, Ambient Temperature	20 °C 68 °F
Average Power, Ambient Temperature	40 °C 104 °F

Return Loss/VSWR

Frequency Band	VSWR	Return Loss (dB)
45-1000 MHz	1.02	39.00
1010-2200 MHz	1.03	38.00
2210-2500 MHz	1.04	35.00

Regulatory Compliance/Certifications

Agency	Classification
RoHS 2011/65/EU	Compliant by Exemption
China RoHS SJ/T 11364-2006	Above Maximum Concentration Value (MCV)
ISO 9001:2008	Designed, manufactured and/or distributed under this quality management system



* Footnotes

Immersion Depth	Immersion at specified depth for 24 hours
Insertion Loss, typical	$0.05\sqrt{\text{freq (GHz)}}$ (not applicable for elliptical waveguide)