

# Product Specifications

AL7E78-PS

7/8 in EIA Flange Positive Stop™ for 1-5/8 in AVA7-50, AL7-50 and LDF7-50A coaxial cable



## CHARACTERISTICS

### General Specifications

---

Interface	7/8 in EIA Flange
Body Style	Straight
Brand	HELIAX <sup>®</sup>
Mounting Angle	Straight

### Electrical Specifications

---

Connector Impedance	50 ohm
Operating Frequency Band	0 – 2500 MHz
Cable Impedance	50 ohm
3rd Order IMD	-120 dBm @ 1800 MHz
3rd Order IMD Test Method	Two +43 dBm Carriers
RF Operating Voltage, maximum (vrms)	2120.00 V
dc Test Voltage	6000 V
Outer Contact Resistance, maximum	1.50 mOhm
Inner Contact Resistance, maximum	1.50 mOhm
Insulation Resistance, minimum	5000 MOhm
Average Power	2.3 kW @ 900 MHz
Peak Power, maximum	90.00 kW
Insertion Loss, typical	0.05 dB
Shielding Effectiveness	-130 dB

# Product Specifications

AL7E78-PS

## Outline Drawing

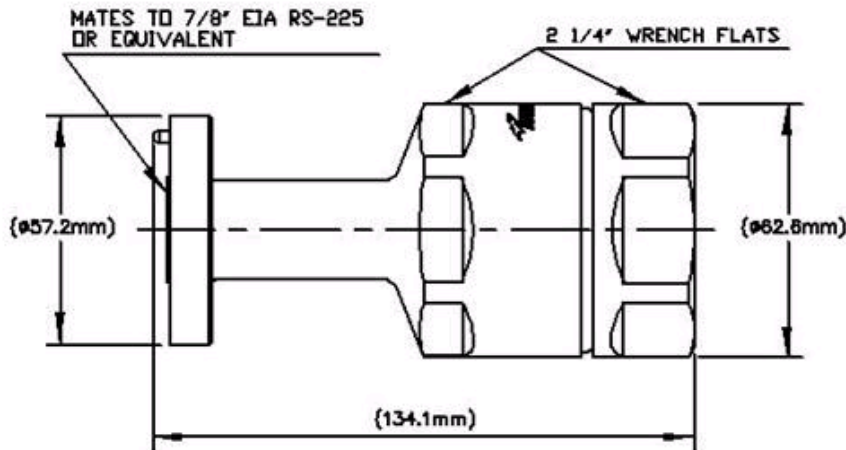

## Mechanical Specifications

Outer Contact Attachment Method	Ring-flare
Inner Contact Attachment Method	Captivated
Outer Contact Plating	Trimetal
Inner Contact Plating	Silver
Attachment Durability	25 cycles
Interface Durability	50 cycles
Connector Retention Tensile Force	2224 N   500 lbf
Connector Retention Torque	13.56 N-m   120.00 in lb
Pressurizable	No

## Dimensions

Nominal Size	1-5/8 in
Diameter	62.64 mm   2.47 in
Length	134.12 mm   5.28 in
Weight	1097.40 g   2.42 lb

## Environmental Specifications

Operating Temperature	-55 °C to +85 °C (-67 °F to +185 °F)
Storage Temperature	-55 °C to +85 °C (-67 °F to +185 °F)
Immersion Depth	1 m

# Product Specifications



AL7E78-PS

Immersion Test Mating	Mated
Immersion Test Method	IEC 60529:2001, IP68
Water Jetting Test Mating	Mated
Water Jetting Test Method	IEC 60529:2001, IP66
Moisture Resistance Test Method	MIL-STD-202, Method 106
Mechanical Shock Test Method	MIL-STD-202, Method 213, Test Condition I
Thermal Shock Test Method	MIL-STD-202F, Method 107G, Test Condition A-1, Low Temperature -55 °C
Vibration Test Method	MIL-STD-202, Method 204, Test Condition B
Corrosion Test Method	MIL-STD-1344A, Method 1001.1, Test Condition A

## Standard Conditions

---

Attenuation, Ambient Temperature	20 °C   68 °F
Average Power, Ambient Temperature	40 °C   104 °F

## Return Loss

---

Frequency Band	VSWR	Return Loss (dB)
45–1000 MHz	1.04	35.00
1010–2200 MHz	1.04	35.00
2210–2500 MHz	1.07	30.00

## \* Footnotes

---

Immersion Depth	Immersion at specified depth for 24 hours
Insertion Loss, typical	$0.05\sqrt{\text{freq (GHz)}}$ (not applicable for elliptical waveguide)