

POWERED BY

**AL7NF-PSA****Type N Female Positive Stop™ for 1-5/8 in cable**

## General Specifications

Interface	N Female
Body Style	Straight
Brand	HELIAX®   Positive Stop™
Mounting Angle	Straight

## Electrical Specifications

Connector Impedance	50 ohm
Operating Frequency Band	0 – 2700 MHz
Cable Impedance	50 ohm
3rd Order IMD, typical	-116 dBm @ 910 MHz
3rd Order IMD Test Method	Two +43 dBm carriers
RF Operating Voltage, maximum (vrms)	707.00 V
dc Test Voltage	2000 V
Outer Contact Resistance, maximum	0.30 mOhm
Inner Contact Resistance, maximum	2.00 mOhm
Insulation Resistance, minimum	5000 MOhm
Average Power	0.6 kW @ 900 MHz
Peak Power, maximum	10.00 kW
Insertion Loss, typical	0.05 dB
Shielding Effectiveness	-130 dB

AL7NFPSA

POWERED BY



## Outline Drawing

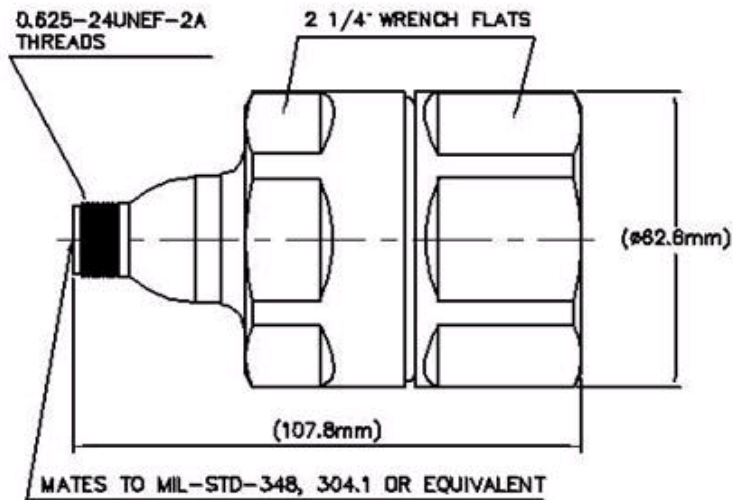

## Mechanical Specifications

Outer Contact Attachment Method	Ring-flare
Inner Contact Attachment Method	Captivated
Outer Contact Plating	Trimetal
Inner Contact Plating	Gold
Attachment Durability	25 cycles
Interface Durability	500 cycles
Interface Durability Method	IEC 61169-16:9.5
Connector Retention Tensile Force	2224 N   500 lbf
Connector Retention Torque	13.56 N-m   120.00 in lb
Insertion Force	66.72 N   15.00 lbf
Insertion Force Method	MIL-C-39012C-3.12, 4.6.9
Pressurizable	No

## Dimensions

Nominal Size	1-5/8 in
Diameter	62.74 mm   2.47 in
Length	107.81 mm   4.24 in
Weight	753.00 g   1.66 lb

## Environmental Specifications

Operating Temperature	-55 °C to +85 °C (-67 °F to +185 °F)
Storage Temperature	-55 °C to +85 °C (-67 °F to +185 °F)
Immersion Depth	1 m
Immersion Test Mating	Unmated

AL7NFPSA



Immersion Test Method	IEC 60529:2001, IP68
Water Jetting Test Mating	Unmated
Water Jetting Test Method	IEC 60529:2001, IP66
Moisture Resistance Test Method	MIL-STD-202F, Method 106F
Mechanical Shock Test Method	MIL-STD-202F, Method 213B, Test Condition C
Thermal Shock Test Method	MIL-STD-202F, Method 107G, Test Condition A-1, Low Temperature -55 °C
Vibration Test Method	IEC 60068-2-6
Corrosion Test Method	MIL-STD-1344A, Method 1001.1, Test Condition A

## Standard Conditions

Attenuation, Ambient Temperature	20 °C   68 °F
Average Power, Ambient Temperature	40 °C   104 °F

## Return Loss/VSWR

Frequency Band	VSWR	Return Loss (dB)
45–400 MHz	1.02	39.00
401–805 MHz	1.02	39.00
806–960 MHz	1.02	39.00
961–1709 MHz	1.03	36.00
1710–2170 MHz	1.04	35.00
2170–2399 MHz	1.07	30.00
2400–2700 MHz	1.08	28.00

## Regulatory Compliance/Certifications

Agency	Classification
RoHS 2011/65/EU	Compliant by Exemption
China RoHS SJ/T 11364-2006	Above Maximum Concentration Value (MCV)
ISO 9001:2008	Designed, manufactured and/or distributed under this quality management system



## \* Footnotes

Immersion Depth	Immersion at specified depth for 24 hours
Insertion Loss, typical	$0.05\sqrt{\text{freq}}$ (GHz) (not applicable for elliptical waveguide)