

# ENVELOPE / ASSEMBLY DRAWING

000000

## SPECIFICATION CONTROL DRAWING

THIS DRAWING CONTAINS INFORMATION PROPRIETARY TO RF INDUSTRIES, LTD. ANY UNAUTHORIZED USE OF THIS DRAWING IS EXPRESSLY PROHIBITED. ANY VIOLATION IS PUNISHABLE UNDER U.S. COPYRIGHT LAWS.

REV	DESCRIPTION	DWN	DATE	APPROVED
A1	ENGINEERING RELEASE	KMM	6/14/93	J. BENZ
B	ENGINEERING RELEASE	KMM	11/7/95	R. RICE
C	ADD NOTE TO CONTACT ITEM #2 / CHG FORMAT	CZS	10/28/97	R. RICE
D	CHANGE BODY ID / REMOVE P/N / LOOSEN TOLERANCES	CZS	8/9/99	R. RICE

ALL DIMENSIONS ARE REFERENCE ONLY

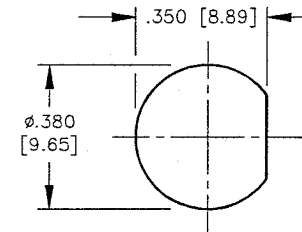
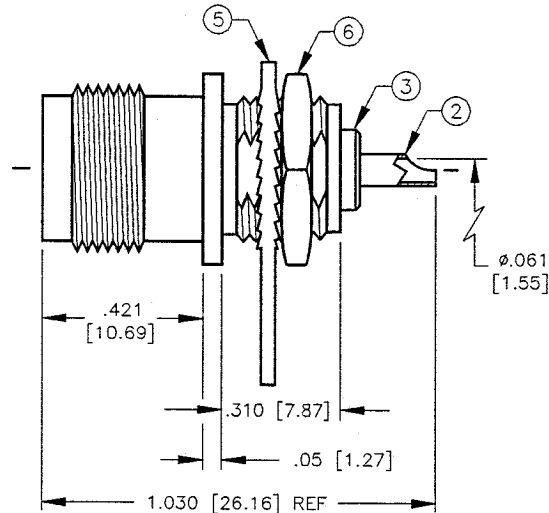

SUGGESTED MOUNTING CONFIGURATION

### SPECIFICATIONS:

IMPEDANCE: 50 OHMS  
 WORKING VOLTAGE: 500 VRMS @ SEA LEVEL  
 FREQUENCY RANGE: 0-7 GHz  
 INTERFACE PER MIL-STD-348, SECTION 313.2

DIMENSIONS ARE IN INCHES AND [MILLIMETERS]

UNLESS OTHERWISE NOTED TOLERANCES ARE:  
 DECIMALS DIAMETER

**RF connectors**  
 DIVISION OF RF INDUSTRIES, LTD.

7610 MIRAMAR RD  
 SAN DIEGO, CA 92126  
 (858) 549-6340  
 (858) 549-6345 FAX

## RFT-1211-1

TNC FEMALE BULKHEAD, FRONT MOUNT

ITEM	DESCRIPTION	QTY	MATERIAL	FINISH
6	HEX NUT	1	BRASS	NICKEL
5	LOCKING SOLDER LUG	1	BRASS	NICKEL
4	PRESS FIT WASHER	1	BRASS	NICKEL
3	DIELECTRIC	1	TEFLON	NONE
2	CONTACT	1	BRASS	GOLD
1	BODY	1	BRASS	NICKEL

DRAWN C. ZUNIGA	8/9/99
CHECKED <i>[Signature]</i>	8/11/99
OR'D DRAWN D. FRIAS	11/24/87

SIZE	CABLE GROUP	DWG NO.	REV
A	N/A	8140	D

APPROVALS	DATE	SCALE:	CAD FILE	SHEET
		2:1	13ARC B	1 OF 1