

# M68729

220-245MHz, 12.5V, 30W, FM MOBILE RADIO

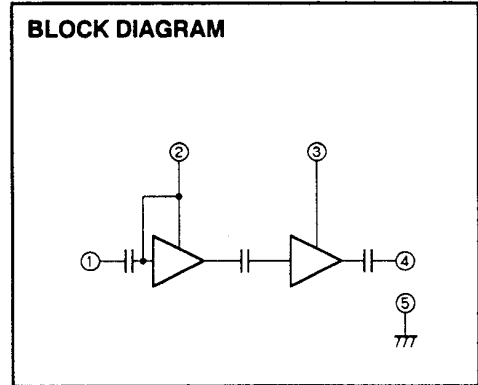
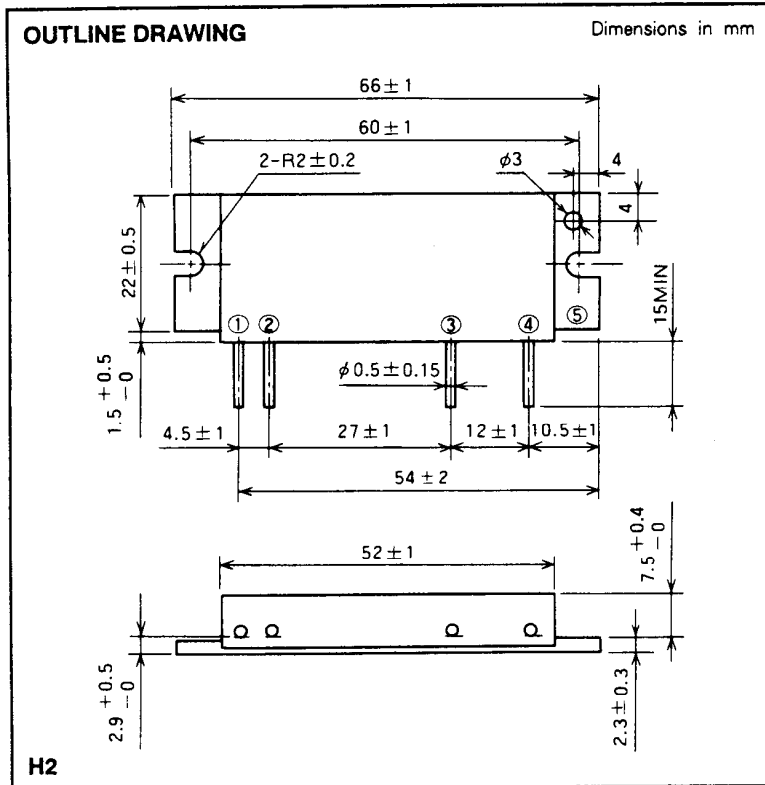

- PIN :
- ① Pin : RF INPUT
  - ② Vcc1 : 1st. DC SUPPLY
  - ③ Vcc2 : 2nd. DC SUPPLY
  - ④ Po : RF OUTPUT
  - ⑤ GND : FIN

**ABSOLUTE MAXIMUM RATINGS** (Tc = 25°C unless otherwise noted)

Symbol	Parameter	Conditions	Ratings	Unit
Vcc	Supply voltage		17	V
Icc	Total current		10	A
P <sub>in(max)</sub>	Input power	Vcc1 ≤ 12.5V, Z <sub>G</sub> = Z <sub>L</sub> = 50Ω	600	mW
P <sub>O(max)</sub>	Output power	Z <sub>G</sub> = Z <sub>L</sub> = 50Ω	40	W
T <sub>c(OP)</sub>	Operation case temperature	Z <sub>G</sub> = Z <sub>L</sub> = 50Ω	- 30 to 110	°C
T <sub>stg</sub>	Storage temperature		- 40 to 110	°C

Note. Above parameters are guaranteed independently.

**ELECTRICAL CHARACTERISTICS** (Tc = 25°C unless otherwise noted)

Symbol	Parameter	Test conditions	Limits		Unit
			Min	Max	
f	Frequency range	Vcc = 12.5V P <sub>in</sub> = 300mW Z <sub>G</sub> = Z <sub>L</sub> = 50Ω	220	245	MHz
P <sub>o</sub>	Output power		30		W
η <sub>T</sub>	Total efficiency		40		%
2f <sub>o</sub>	2nd. harmonic			- 30	dBc
3f <sub>o</sub>	3rd. harmonic		- 30	dBc	
ρ <sub>in</sub>	Input VSWR			3	-
-	Load VSWR tolerance	Vcc = 15.2V P <sub>o</sub> = 30W (P <sub>in</sub> : controlled) Load VSWR=20:1 (All phase), Z <sub>G</sub> = 50Ω	No degradation or destroy		-

Note. Above parameters, ratings, limits and conditions are subject to change.

TYPICAL PERFORMANCE DATA

