

M57735

50-54MHz, 12.5V, 19W, SSB MOBILE RADIO

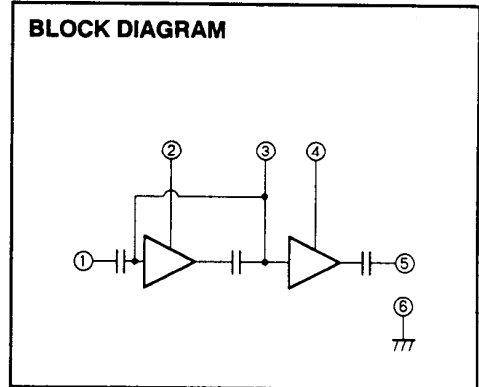
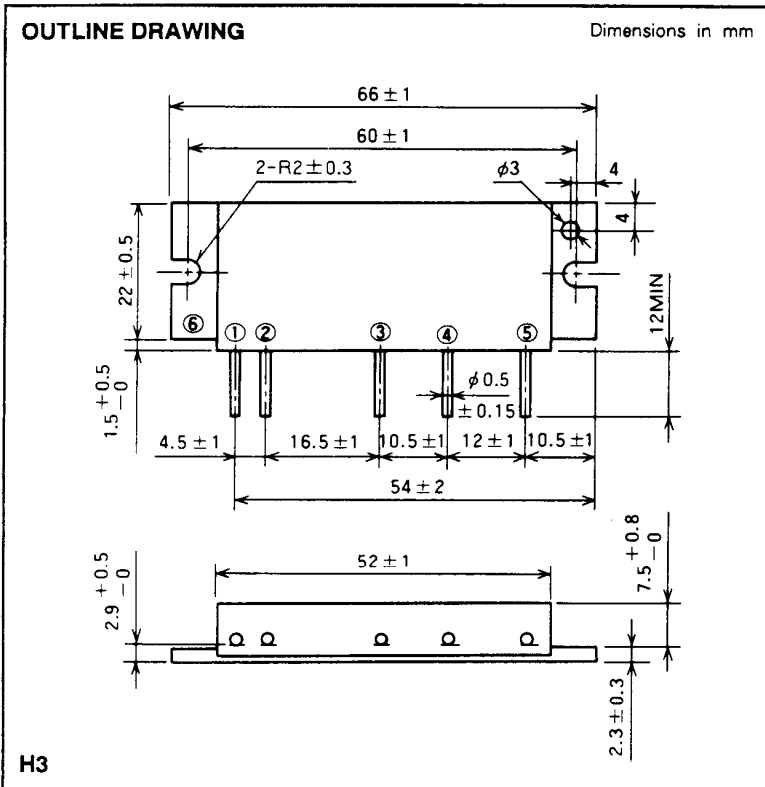

PIN :
 ① P_{in} : RF INPUT
 ② V_{CC1} : 1st. DC SUPPLY
 ③ V_{BB} : BASE BIAS SUPPLY
 ④ V_{CC2} : 2nd. DC SUPPLY
 ⑤ P_o : RF OUTPUT
 ⑥ GND : FIN

ABSOLUTE MAXIMUM RATINGS (T_c = 25°C unless otherwise noted)

| Symbol | Parameter | Conditions | Ratings | Unit |
|----------------------|----------------------------|--|-------------|------|
| V _{CC} | Supply voltage | | 17 | V |
| V _{BB} | Base bias | | 10 | V |
| I _{CC} | Total current | | 6 | A |
| P _{in(max)} | Input power | Z _G = Z _L = 50 Ω | 0.4 | W |
| P _{o(max)} | Output power | Z _G = Z _L = 50 Ω | 25 | W |
| T _{C(OP)} | Operation case temperature | | - 30 to 110 | °C |
| T _{stg} | Storage temperature | | - 40 to 110 | °C |

Note. Above parameters are guaranteed independently.

ELECTRICAL CHARACTERISTICS (T_c = 25°C unless otherwise noted)

| Symbol | Parameter | Test conditions | Limits | | Unit |
|-----------------|---------------------|---|---------------------------|------|------|
| | | | Min | Max | |
| f | Frequency range | P _{in} = 0.2W V _{CC} = 12.5V V _{BB} = 9V Z _G = Z _L = 50 Ω | 50 | 54 | MHz |
| P _o | Output power | | 19 | | W |
| η _T | Total efficiency | | 40 | | % |
| 2f _o | 2nd. harmonic | | | - 25 | dBc |
| 3f _o | 3rd. harmonic | | | - 30 | dBc |
| ρ _{in} | Input VSWR | | | 2.2 | - |
| - | Load VSWR tolerance | V _{CC} = 15.2V, V _{BB} = 9V P _o = 14W (P _{in} : controlled) Load VSWR ≥ 20:1 (All phase) Z _G = 50 Ω | No degradation or destroy | | - |

Note. Above parameters, ratings, limits and conditions are subject to change.

TYPICAL PERFORMANCE DATA

OUTPUT POWER, TOTAL CURRENT, 1st COLLECTOR CURRENT VS. INPUT POWER

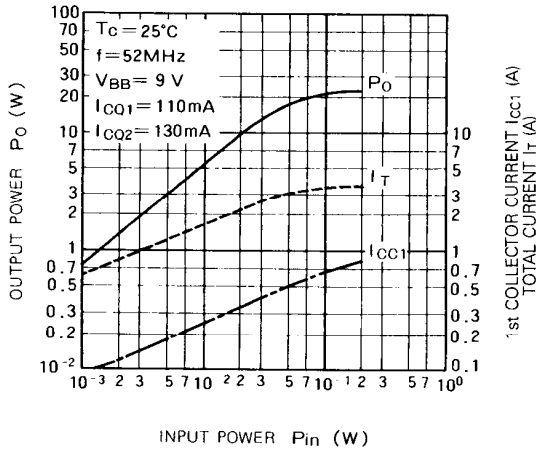

OUTPUT POWER, FINAL COLLECTOR CURRENT VS. 1st SUPPLY VOLTAGE

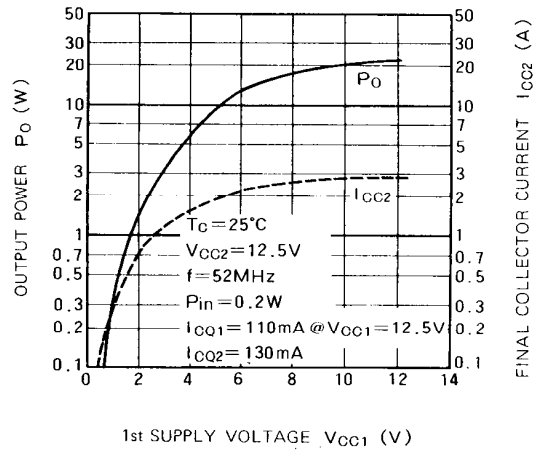

POWER GAIN VS. FREQUENCY

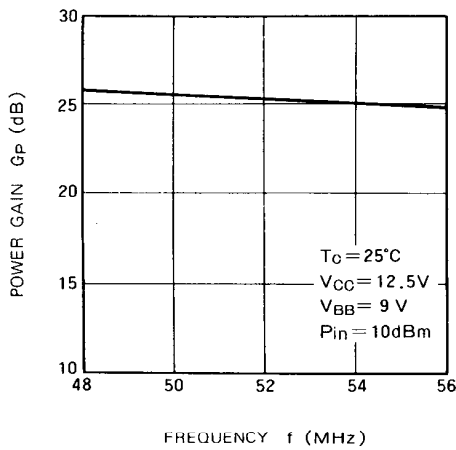

OUTPUT POWER, TOTAL EFFICIENCY, INPUT VSWR VS. FREQUENCY

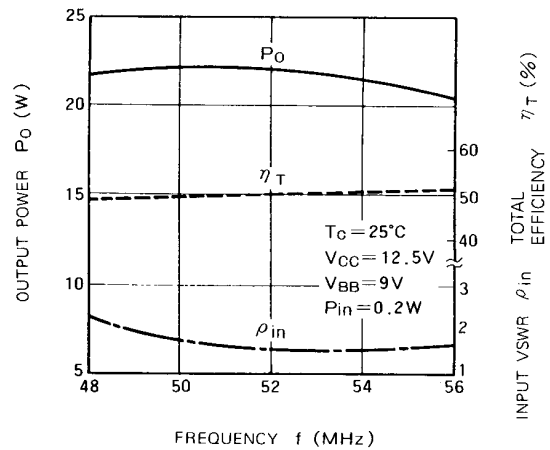

OUTPUT POWER VS. DC SUPPLY VOLTAGE

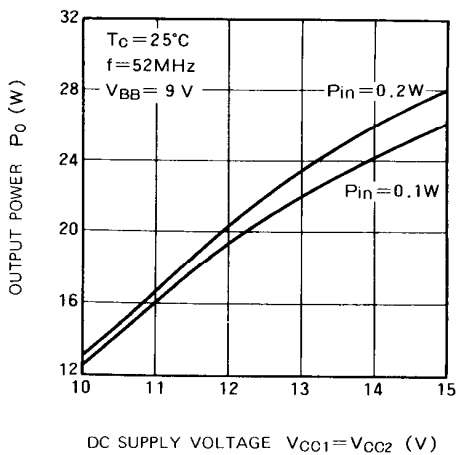

INTERMODULATION DISTORTION VS. OUTPUT POWER

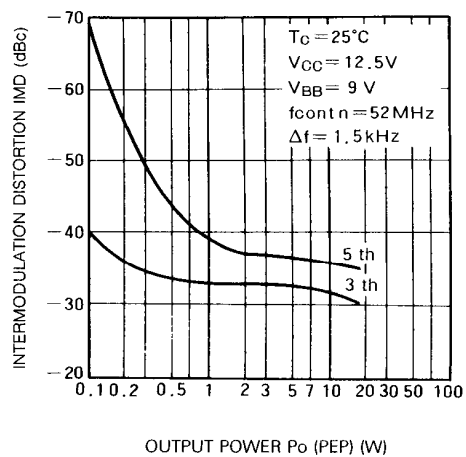

INPUT IMPEDANCE VS. FREQUENCY

